

#94WM-ONE METER (1") RESETTER SAMPLING STATION SPEC SHEET

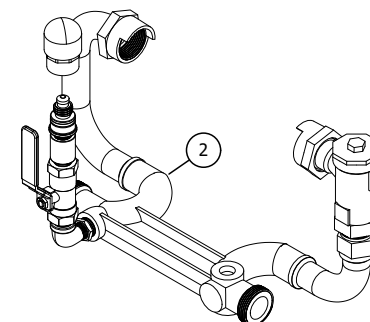
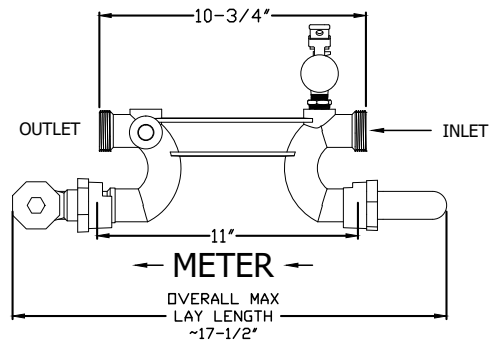
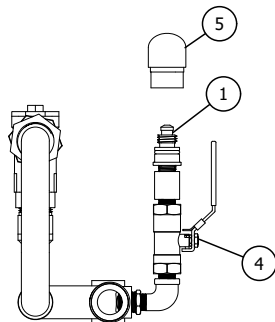
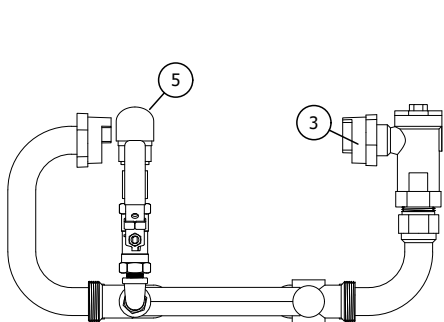

A FRONT VIEW
Scale: 1 1/2"=1'-0"

B SIDE HORN ANGLE VIEW
Scale: 1 1/2"=1'-0"

C WATER FLOW VIEW
Scale: 1 1/2"=1'-0"

D ISOMETRIC VIEW
Scale: 1 1/2"=1'-0"

#94WM-ONE Meter (1") Resetter Sampling Station Spec Sheet shall be installed in the following location(s):

ITEM	DESCRIPTION
1	S.S. MALE SPRING LOADED SAMPLING VALVE
2	94WM BODY (1")
3	1" EPDM RUBBER METER GASKET
4	3/8" LOCKABLE BALL VALVE
5	PVC COVER WITH CAP

Meter Resetter Sampling Station shall be meter box retrofit style for a 1" meter, with 1 1/4" NPS threaded inlet and outlet, both with a face for gasket seal. If desired the dual check valve (brass body) can be replaced with an idler/spacer option to be located between the water meter and residence.

To perform sampling, a portable rod (Kupferle Part # Z94PR) with a female coupler will thread onto the S.S. male spring loaded piston valve (#1) connected to the meter setter. This connection shall require a turning motion only, with no pushing or pulling necessary. Male valve shall be located before the water meter, have an auxiliary shut-off valve, and be protected by a PVC cover when not in use.

Unit model # shall be 94WM-ONE-S-BD as specified in the product ordering guide as manufactured by Kupferle Foundry Company, St. Louis MO, or approved equal.

RESETTER PRODUCT ORDERING GUIDE											
MODEL#	94WM	-	ONE	-	S	-	BD				
SUBSECTION	1		2		3		4				
SUBSECTION DESCRIPTION	MODEL #	SUBSECTION	OPTIONS	DESCRIPTIONS							
MODEL	1		94WM	BRASS RESETTER							
SIZE	2		ONE	1" METER							
			FxT	5/8" x 3/4" METER							
			FxH	5/8" x 1/2" METER							
SAMPLING OPTIONS	3		S	STANDARD SAMPLING ASSEMBLY							
			N	NONE (RESETTER CONFIGURATION)							
LAY LENGTH OPTIONS	4		N	NONE							
			BD	BRASS DUAL CHECK VALVE (INLINE)							

10/13/20	ISSUED FOR REFERENCE	MAXIMUM WORKING WATER PRESSURE: 175 PSI TEMPERATURE RANGE: 32° TO 140°F
DATE	STATUS / REVISION	

	INITIALS	DATE
DRAWN	DCL	10/13/20
APPROVED	DCL	10/30/20
MODIFIED		
	SHEET SIZE	SCALE
	A (11x8.5)	1-1/2"=1'

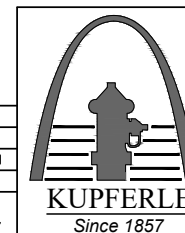

2511 NORTH 9TH STREET
ST. LOUIS, MO 63102
1-800-231-3990
FAX 314-231-2820
www.hydrants.com

#94WM-ONE (1") RESETTER SAMPLING STATION