

# #2 ECLIPSE POST HYDRANT CUT SHEET

(2" FIP INLET, STANDARD TOP STOCK, 2-1/2" NST OUTLET SHOWN)  
NOTE J

## PARTS LIST

ITEM	QTY	PART NUMBER	DESCRIPTION	NOTES
1	4	1/2W	1/2" BOTTOM WASHER	C
2	2	2OR	O-RING FOR PLUNGER STEM	C,K
3	45.875 in	3/4GAL	3/4" GALVANIZED OPERATING ROD	B,C
4	1	487-H	"NEW STYLE" TOP STOCK	C,K,L
5	33.000 in	4FBE	FBE COATED BARREL PIPE	B,C,M
6	1	501A	TOP SCREW	C
7	1	511	CONNECTING NUT	C
8	1	521	SEAT RING	C
9	1	537-P	"NEW STYLE" PLUNGER TOP	C,K
10	1	539L2	PLUNGER STEM	K
11	1	539W	S.S. PLUNGER WASHER	K
12	1	541	SEAT RUBBER	C,K
13	1	571-A	IRON BOTTOM (2" IP)	J,K
14	1	581-C	"NEW STYLE" TOP CAP	C
15	1	592-A	2-1/2" NST SIDE CAP	K
16	1	611	WASTE TUBE	K
17	8	628A-B	TOP CAP BOLT	C
18	8	629A-N	1/2" HEX NUT	C
19	2	668	OPERATING SCREW O-RING	C
20	1	669	PACKING NUT GASKET	C
21	1	678	FLANGE COUPLING FOR DUCTILE	C
22	1	716	2-1/2" NST BRASS NOZZLE	C,J
23	1	739	PACKING NUT	C
24	1	95G	HOUSING O-RING	C
25	2	A16	SIDE CAP GASKET	C,K
26	1	A19	WASTE TUBE O-RING	C,K
27	1	A2-NS	"NEW STYLE" TOP CAP GASKET	C
28	1	A8	"NEW STYLE" VALVE GASKET	C,K
29	1	595	CHAIN ASSEMBLY	A
<b>OPTIONS / REPAIR PARTS LIST</b>				
30	0	1 1/16SR	SOLID OPERATING ROD	A,C
31	0	3/4C	COUPLING FOR OPERATING ROD	A,C
32	0	3/4SSP	SS OPERATING ROD	A,C
33	0	667	HANDWHEEL - 1-1/2" PENT	C
34	0	674	"NEW STYLE" LOCKING WRENCH	C

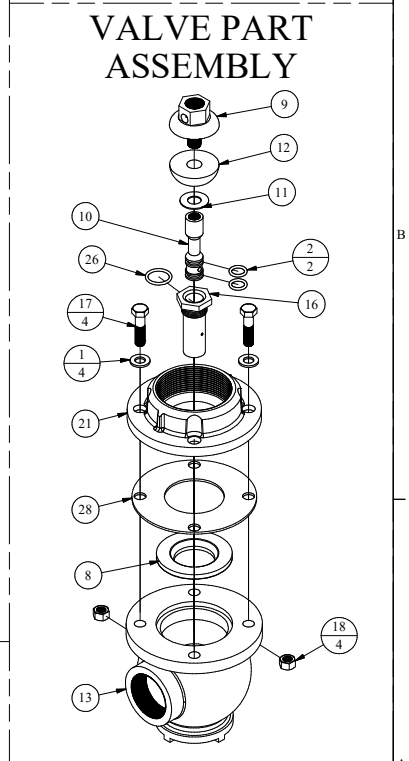
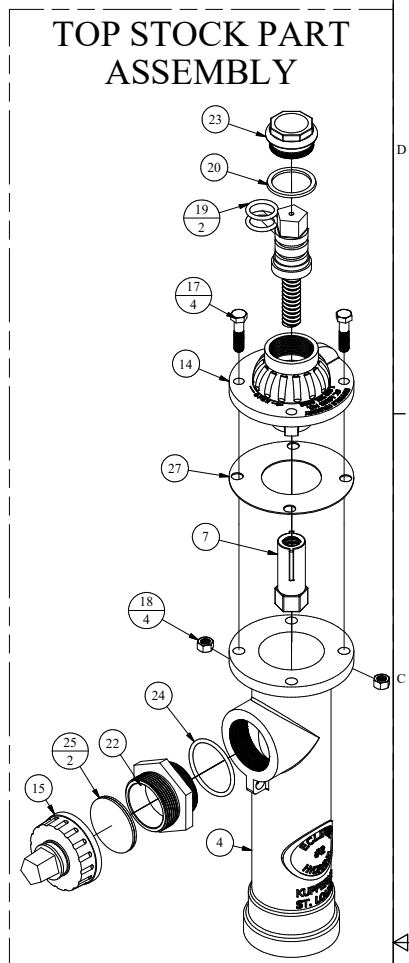
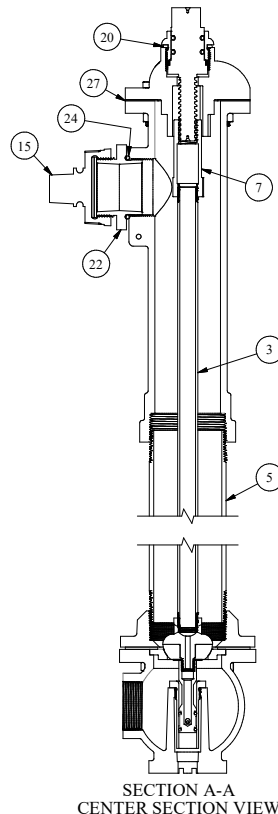
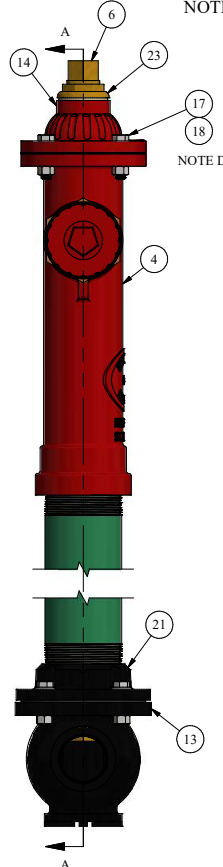

## REPAIR KITS

PART NUMBER	DESCRIPTION	PARTS INCLUDED
X475-XX	EXTENSION - 6" INCREMENTS	4FBE EXTERIOR PIPE, 3/4GAL OPERATING ROD, 3/4C COUPLING (1), 678 COUPLING (2), 628A-B BOLT (4), 629A-N NUT (4), A8 GASKET (1)
X501A	1-1/2" PENT TOP SCREW COMPLETE	501A TOP SCREW (1) 1-1/2" PENT (1), 668 O-RING (2)
X503VP	VANDAL PROOF SCREW COMPLETE	503-VP VANDAL PROOF SCREW (1), 668 O-RING (2)
X581C	IRON TOP CAP COMPLETE	581-C "NEW STYLE" TOP CAP (1), A2-NS GASKET (1), 628A-B BOLT (4), 629A-N NUT (4)
X581C-1	"NEW STYLE" BONNET COMPLETE	581-C TOP CAP (1), 501A TOP SCREW (1), 668 O-RING (2), 739 PACKING NUT (1), 669 GASKET (1), 511 CONNECTING NUT (1), A2-NS GASKET (1), 628A-B BOLT (4), 629A-N NUT (4)
X739	1-1/2" PENT PACKING NUT WITH GASKET	739 PACKING NUT (1), 669 GASKET (1)

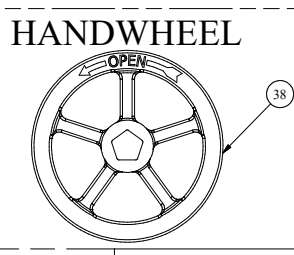
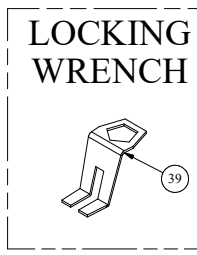

NOTE	DESCRIPTION
A	NOT SHOWN
B	PIPE LENGTH DEPENDENT ON DEPTH OF BURY, SHOWN AS 3' DOB
C	SOLD AS REPLACEMENT PART
D	BOLT ASSEMBLY USED ON ALL SIMILAR HOLES/BRACKETS
J	SEVERAL OTHER INLET/OUTLET CONFIGURATIONS ARE OFFERED. SEE NOTES K & L
K	SEE #2, #8, #85 GUIDE FOR INLET, NOZZLE, CAP OPTIONS, & PLUNGER HISTORY SHEET FOR ASSEMBLY VIEWS AND REPLACEMENT PART INFORMATION
L	SEE #2 GUIDE FOR TOPS STOCK OPTIONS AND OLD STYLE PARTS REPAIR KITS
M	BARREL PIPE FUSION BONDED EPOXY COATED, BOTH INTERNALLY AND EXTERNALLY

## LEGEND

- (X) → STANDARD TAG
- (X/Y) → TAG WITH Y QUANTITY

**DISCLAIMER:**  
THIS DRAWING IS THE PROPERTY OF THE KUPFERLE FOUNDRY COMPANY. IT IS NOT TO BE USED OR DUPLICATED WITHOUT THE PERMISSION OF THE OWNER.

DRAWN	SMS	5/2/2017		
CHECKED	DCL	11/14/2017		
MODIFIED	ADC	3/18/2026		
SIZE	C	SCALE		1 / 5
DWG NO	#2 Cut_Rev0.2		2511 NORTH 9TH ST. ST. LOUIS, MO 63102 1-800-231-3990	
			SHEET	REV
			1 OF 1	0.3