

MainGuard #66WC

Stainless Steel Sample Station for Warm Climates



About the MainGuard #66WC

- Corrosion resistant lockable enclosure
- No drain or threads to prevent contamination
- Designed for use in warm climates
- Separate blow-off and sampling tap
- Fully maintainable from above ground

Getting More Specific...

- 1/4" unthreaded sample bibb
- 1/2" MIP inlet connection
- All surgical stainless steel waterway
- Lockable, fabricated aluminum enclosure
- Can accommodate any bury depth in 6" increments
- Optional powder-coat paint options available
- Choose buried or bolted-flange enclosure



#66WC SAMPLING STATION SPEC SHEET

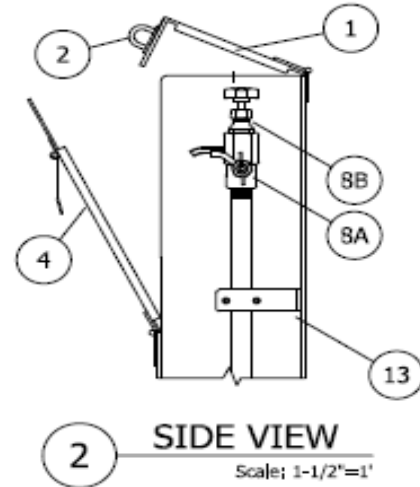
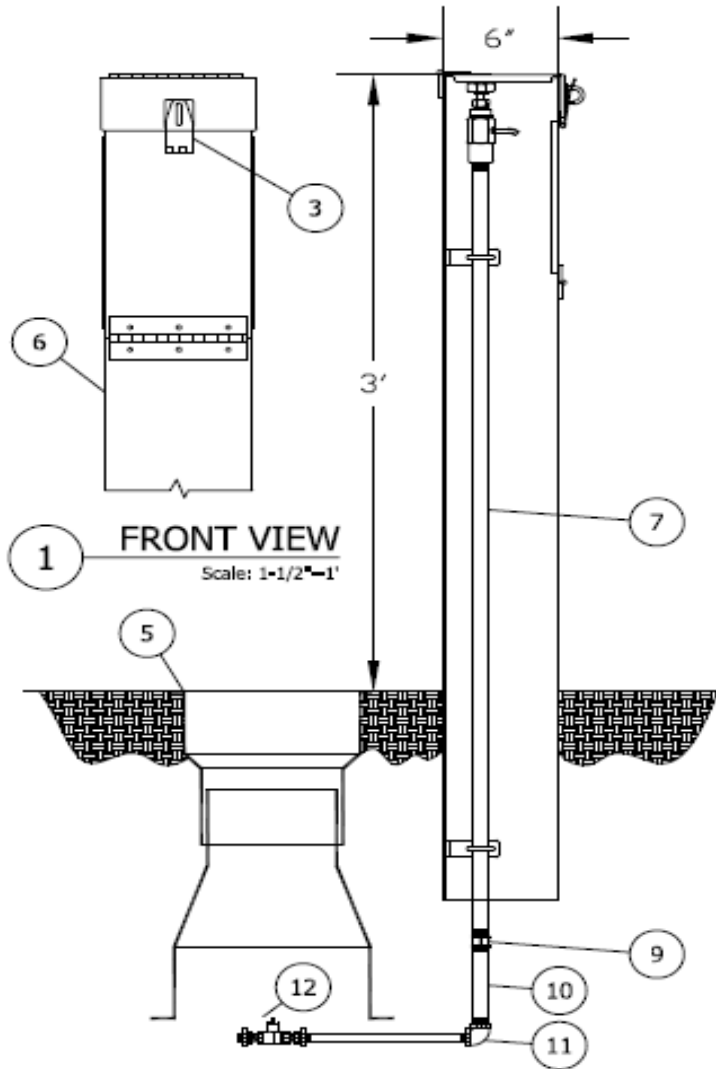

#66WC SAMPLING STATION TO BE INSTALLED AT THE FOLLOWING LOCATIONS:

NOTES:

IN SOME CONDITIONS CORROSION OF STAINLESS STEEL CAN OCCUR (EXPOSURE TO SALT WATER, DIRECT EXPOSURE TO STRONG CHLORIDES, ETC.). PROPER MAINTENANCE OF THE EXPOSED STAINLESS STEEL PARTS USING PROPER STAINLESS STEEL CLEANING AGENTS WILL INCREASE THE LIFESPAN OF THE HYDRANT. IF DESIRED, KUPFERLE CAN ALSO OFFER AN ADDITIONAL PASSIVATION PROCESS FOR ADDITIONAL CORROSION PROTECTION.

#66WC SAMPLING STATION SHALL BE 1' BURY WITH A 1/2" MIP INLET AND A 7/16" UNTHREADED BLOW OFF. ALL STATIONS SHALL BE ENCLOSED IN A LOCKABLE, NON-REMOVABLE 6" SQUARE ALUMINUM HOUSING. ALL OPENINGS SHALL BE HINGED. STATION SHALL REQUIRE NO KEY FOR OPERATION. AN OPERATING VALVE SHALL CONTROL THE FLOW OF WATER THRU THE 7/16" OUTLET, WITH 6 ROTATIONS OF THE HANDLE BEING FULLY OPEN. ALL WATER FLOW SHALL PASS THRU AN ALL STAINLESS STEEL WATERWAY. ALL WORKING PARTS SHALL BE OF STAINLESS STEEL AND SERVICEABLE ABOVE GROUND WITH NO DIGGING OR REPLACEMENT NEEDED.

ITEM	ITEM / DESCRIPTION	NOTES	OPTIONAL
1	TOP ACCESS DOOR		
2	PADLOCK EYE		
3	PADLOCK HASP		
4	FRONT ACCESS DOOR		
5	VALVE BOX	BY OTHERS	
6	6" ALUMINUM SQUARE BOX		
7	1/2" S.S. WATERWAY		
8A	SAMPLING BIBB		
8B	OPERATING VALVE		
9	1/2" S.S. COUPLING	BY OTHERS	X
10	1/2" S.S. NIPPLE	BY OTHERS	X
11	1/2" S.S. ELBOW	BY OTHERS	X
12	HYDRANT SHUT-OFF VALVE	BY OTHERS	X
13	MOUNTING BRACKET		
14	OPERATING VALVE		



Kupferle Water Solutions
hydrants.com
314.231.8738

