

TF100-P TRUFLO POST HYDRANT MODERN CASING GUARD

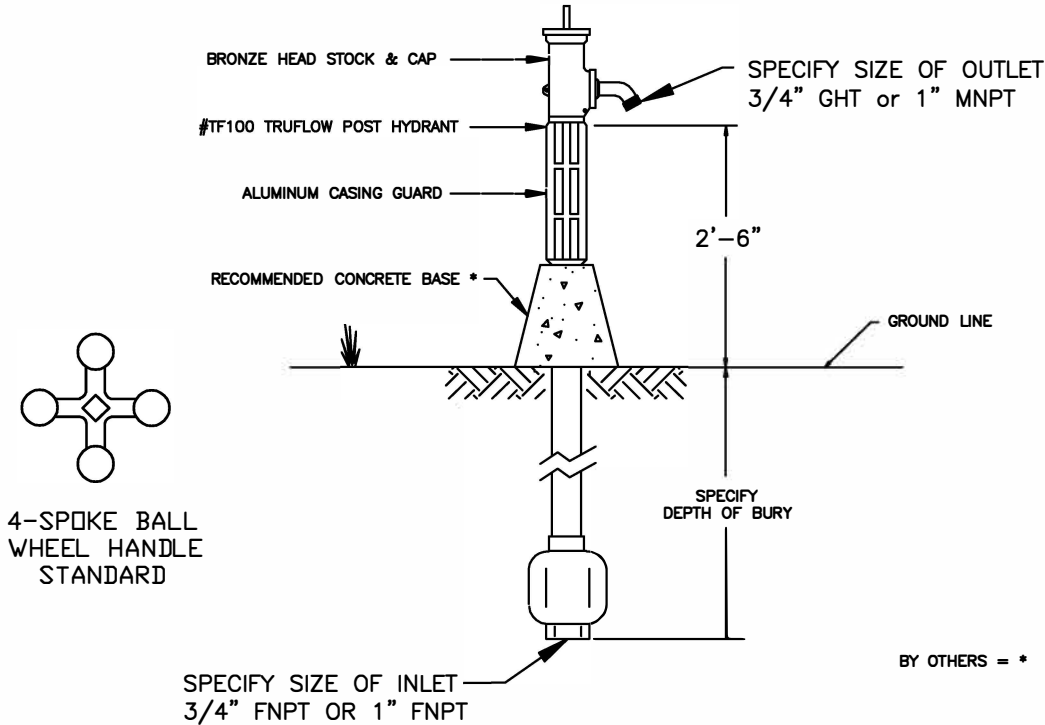

Hydrant shall be ____ ' Depth of Bury with a 3/4" or 1" FNPT vertical inlet and a 3/4" GHT or 1" MNPT outlet.

Hydrant shall be non-freezing, self draining. Hydrant shall have a bronze head and cap, aluminum casing guard, a (galvanized steel (STD), stainless steel or brass) exterior casing pipe, a (brass (STD), stainless steel or galvanized steel) non-turning interior operating rod and bronze valve body. Hydrant shall be operated by 5/8" square operating nut with a 4-spoke ball wheel operating handle.

Hydrant must seal the drain outlet in all positions from 1/4 closed to fully open. All internal; working part shall be removable from above ground with no digging required.

Hydrant shall be set in 4 cubic feet of crushed stone to allow for proper drainage of the hydrant, Recommendations of the AWWA should be followed for installation of the hydrants.

Hydrant shall be Model TF100 TruFlow Post Hydrant as manufactured by the Kuperle Foundry Company, St. Louis, MO 63102 or approved equal.

		<p>THIS DRAWING IS THE PROPERTY OF THE KUPFERLE FOUNDRY COMPANY. IT IS NOT TO BE USED OR DUPLICATED WITHOUT PERMISSION OF THE OWNER.</p>	<table border="1" style="width: 100%; border-collapse: collapse;"> <tr><td style="font-size: small;">DRAWN</td><td style="font-size: x-small;">G.B.</td></tr> <tr><td style="font-size: small;">APPROVED</td><td></td></tr> <tr><td style="font-size: small;">DATE</td><td></td></tr> <tr><td style="font-size: small;">MAT'L</td><td></td></tr> </table>	DRAWN	G.B.	APPROVED		DATE		MAT'L		<p style="font-weight: bold; font-size: small;">KUPFERLE FOUNDRY COMPANY</p> <p style="font-size: x-small;">2511 NORTH 9TH STREET, ST. LOUIS, MO 63102 314-231-8738 800-231-3900 FAX 314-231-2820 http://www.hydrants.com</p>
DRAWN	G.B.											
APPROVED												
DATE												
MAT'L												
DATE	REVISION	PART NO. TF100 TRUFLO YARD HYDRANT										