

#TF-100 CUT SHEET

(#TF-100-B STANDARD SHOWN)

PARTS LIST

ITEM	QTY	PART NUMBER	DESCRIPTION	NOTES
1	5.16	1 1/4P	1-1/4" STEEL PIPE (BARREL PIPE)	B,C
2	5.29	1/2P	1/2" STEEL PIPE (OPERATING ROD)	B,C
3	1	10101	BRASS INLET VALVE	C
4	1	10102	IRON TOP CAP (TF100)	C
5	1	10103	IRON HEADSTOCK (TF100)	C
6	1	10105	PLUNGER	
7	1	10106	PLUNGER BOLT	
8	1	10122	TOP CAP GASKET	C
9	1	10143	TF100 BRASS WASHER	C
10	1	10220	O-RING FOR TRUFLO SCREW	C
11	1	10241	BRASS CONNECTING NUT	C
12	2	10248	TOP CAP BOLT	
13	1	1699	IRON HANDLE	C
14	3	2019	O-RING FOR PLUNGER	C
15	1	321	1" BRASS NOZZLE	C
16	1	329	SEAT RUBBER	
17	1	500TF	BRASS OPERATING SCREW (1699 HANDLE)	
18	1	77C	HANDLE BOLT	
19	2	77Q-88	TOP CAP NUT	C
20	1	77W	HANDLE WASHER	
21	1	9419	PLUNGER WASHER	

OPTIONAL PARTS LIST

22	0	1 1/4GAL	1-1/4" GALVANIZED PIPE (BARREL PIPE-5.16FT)	A,B,C
25	0	1/2BP	1/2" BRASS PIPE (OPERATING ROD-5.29 FT)	A,B,C
23	0	1 X 3/4BA	1" x 3/4" GHT BRASS ADAPTER	A
24	0	1 X 3/4BHB	1" x 3/4" BRASS HEX BUSHING	A
26	0	10102-B	BRASS TOP CAP (TF100)	C
27	0	10103-B	BRASS HEADSTOCK (TF100)	C
28	0	10157	ALUMINUM GUARDS	C
29	0	10258	ALLEN SET SCREW	C
30	0	10259	ALLEN SCREW	C
31	0	182	3/4" IRON CASING GUARD	C
32	0	345-N-500	CASING GUARD NUT	C
33	0	345-S	CASING GUARD SCREW	C

REPAIR KITS

PART NUMBER	DESCRIPTION	PARTS INCLUDED
X10105	TF100 PLUNGER COMPLETE	10105 PLUNGER (1), 2019 O-RING (3), 329 SEAT (1), 9419 WASHER (1), 10106 BOLT (1)
X500TF	BRASS TOP SCREW FOR HANDLE COMPLETE	500TF BRASS TOP SCREW (1), 10220 O-RING (2)
XTF100RK	TF100 REPAIR KIT	10105 PLUNGER (1), 2019 O-RING (3), 329 SEAT (1), 9419 WASHER (1)

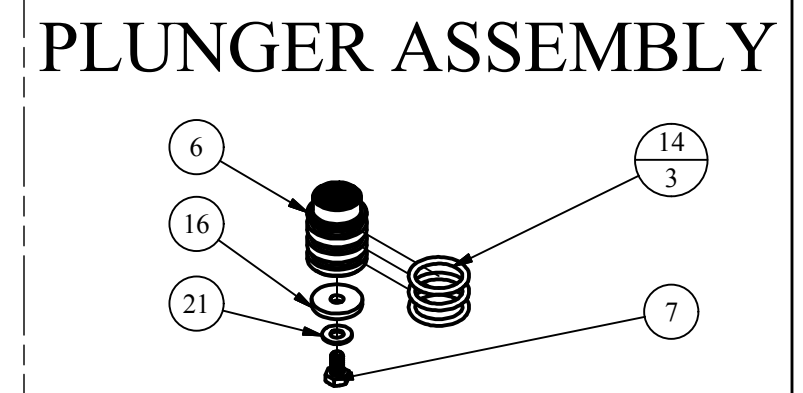
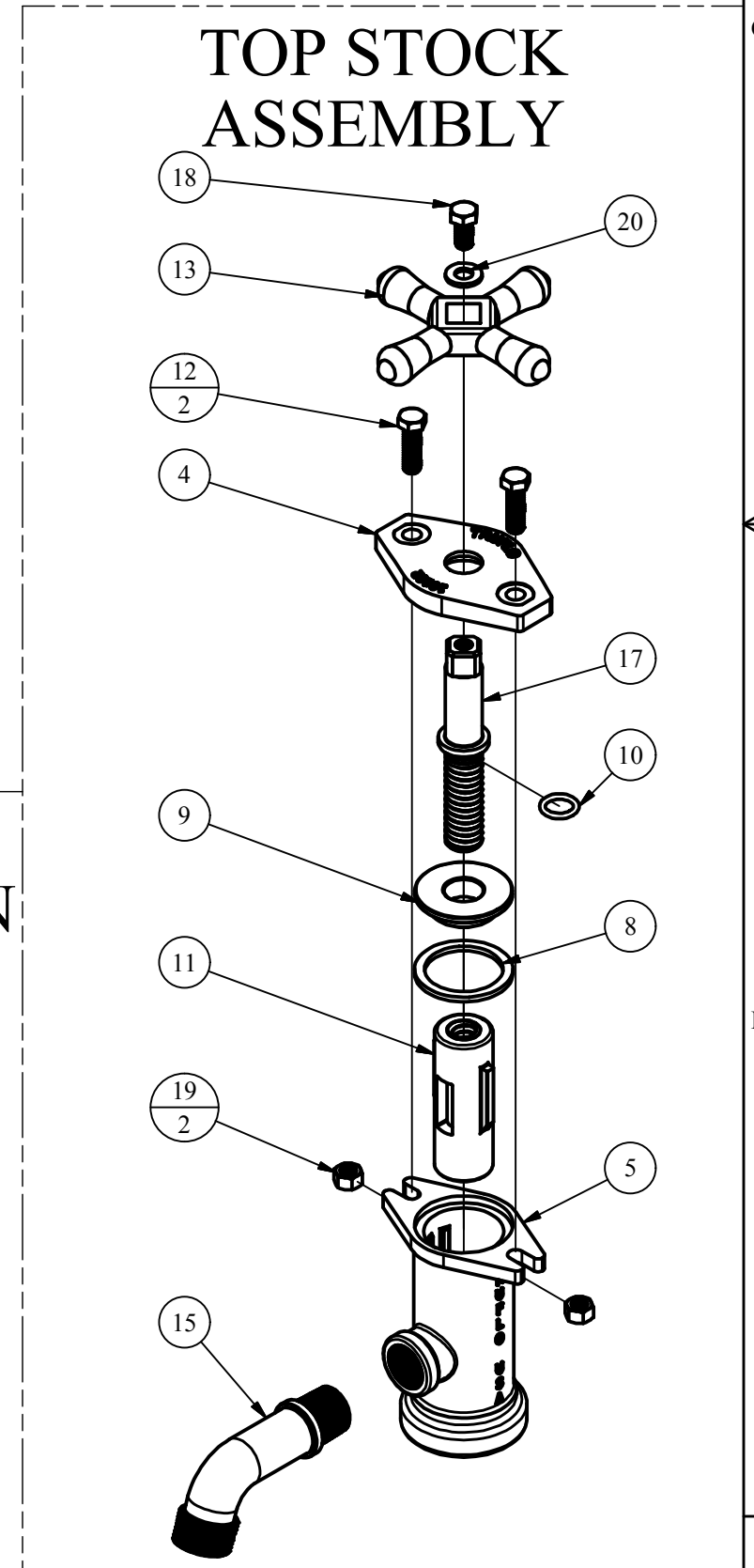
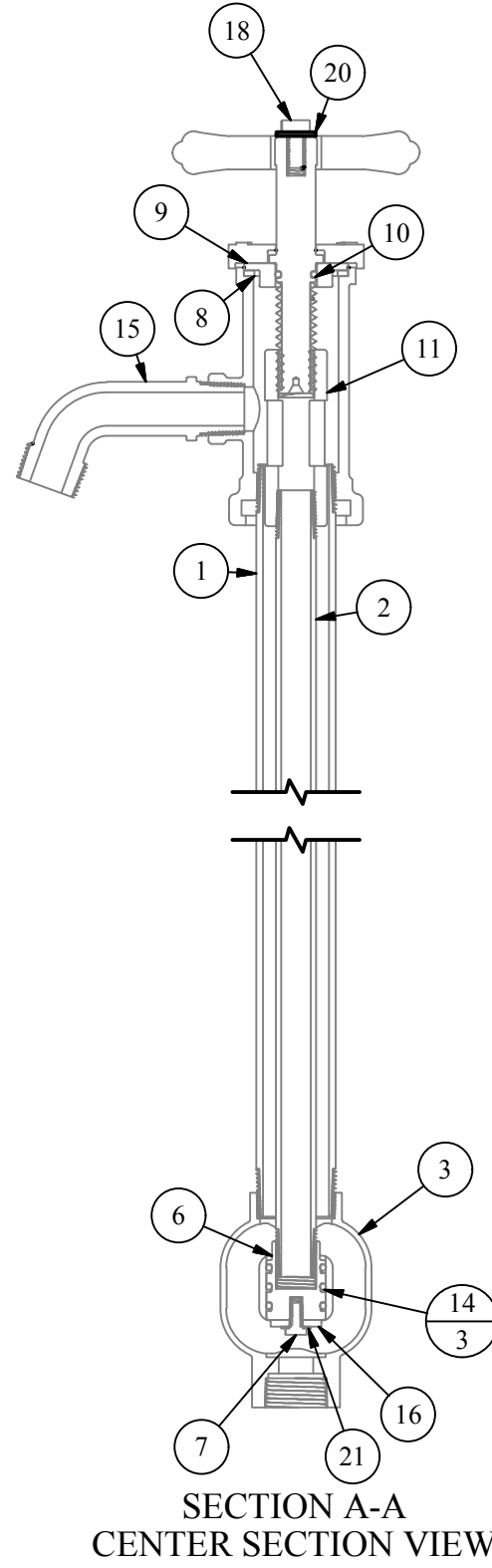
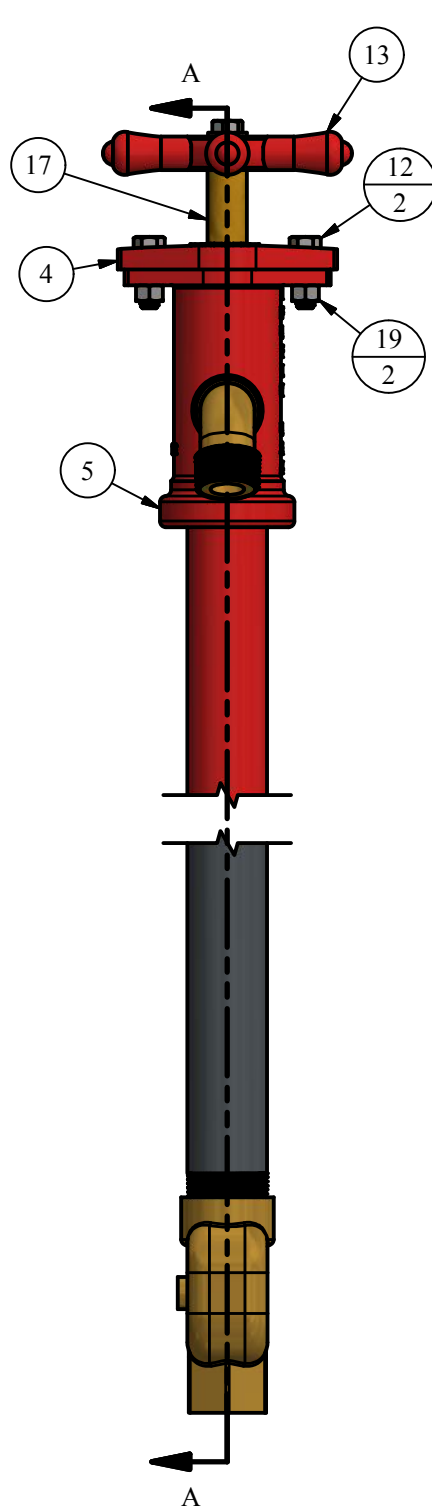

#TF-100-O YARD HYDRANT

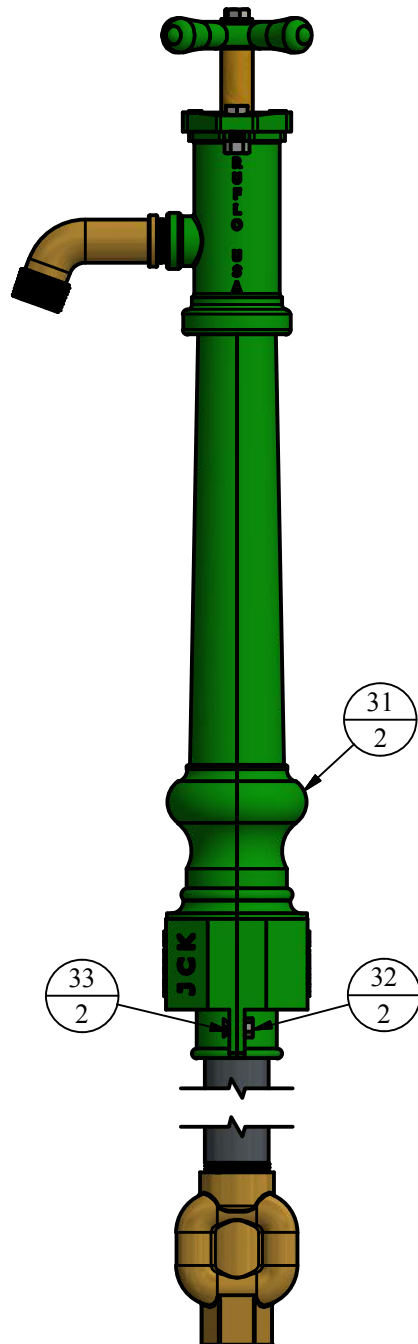

#TF-100-P PLANT WASHDOWN

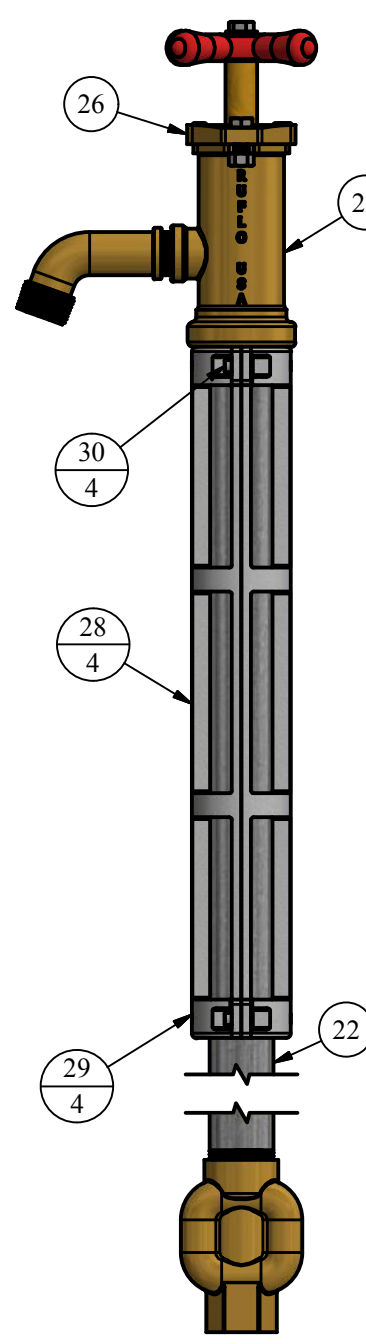

NOTE	DESCRIPTION
A	NOT SHOWN
B	PIPE LENGTH DEPENDENT ON DEPTH OF BURY
C	SOLD AS REPLACEMENT PART

DISCLAIMER:
THIS DRAWING IS THE PROPERTY OF THE KUPFERLE
FOUNDRY COMPANY. IT IS NOT TO BE USED OR
DUPLICATED WITHOUT THE PERMISSION OF THE OWNER.

LEGEND

(X)	STANDARD TAG
(X/Y)	TAG WITH Y QUANTITY

DRAWN	11/3/2017
CHECKED	
DCL	1/26/2018
MODIFIED	

SIZE	SCALE
C	1 / 4

DWG NO	#TF-100 Cut Rev_0
--------	-------------------



SHEET	REV
1 OF 1	0