

#9800i-CC : INTELLIGENT PERMANENT FLUSHING STATION

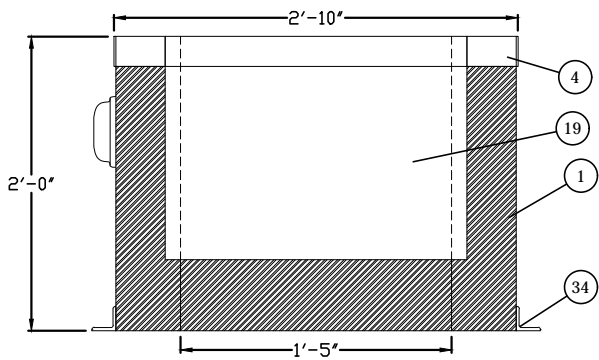

A ENCLOSURE - CLOSED (FRONT)

Scale: 3/4"=1'-0"

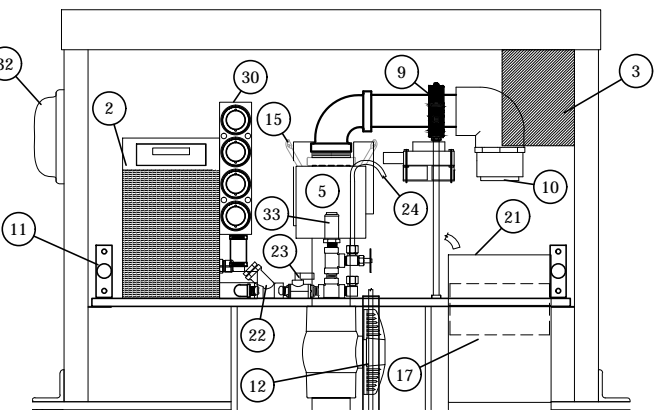

B ENCLOSURE - CUT VIEW (FRONT)

Scale: 1"=1'-0"

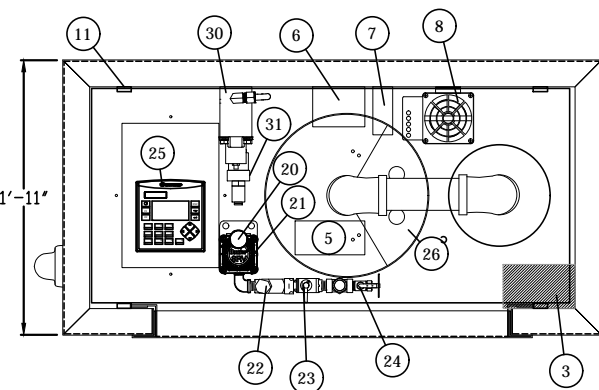

C ENCLOSURE - LID REMOVED (TOP)

Scale: 1"=1'-0"

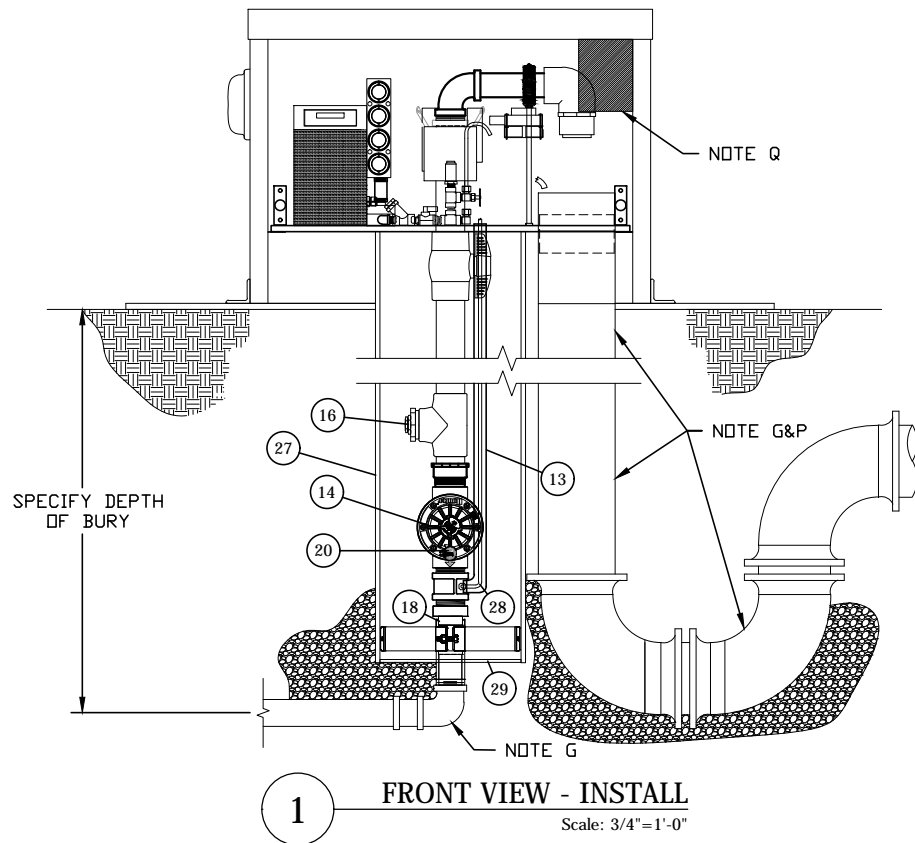

1 FRONT VIEW - INSTALL

Scale: 3/4"=1'-0"

I-SERIES PRODUCT ORDERING GUIDE										
MODEL#	9800i	CC	120	-	+	-	A	-	-	-
SUBSECTION	1	2	3	4	5	6	7	8	9	10
MODEL SHOWN IN VIEW 1: 9800i-CC-120-3.0-A-X-A-AD										
SUBSECTION DESCRIPTION	MODEL #	SUBSECTION	OPTIONS	DESCRIPTIONS						
MODEL	1		9800i	PERMANENT I-SERIES HYDRANT						
CLIMATE	2		CC	COLD CLIMATES						
POWER	3		120	120 VAC						
DEPTH OF BURY	4		0.0	X.X = FEET OF DEPTH OF BURY. ENTER # IN FEET AND INCHES ROUNDED TO NEAREST 0.5 FOOT.						
COMMUNICATION	5		X	NONE						
			A	CELLULAR (RV50 GATEWAY)						
			B	ALARM INDICATION LIGHT						
			C	ETHERNET CARD ADDED						
			D	SECOND SERIAL CARD ADDED						
BACKFLOW PREVENTION	6		X	N/A						
			A	DUCKBILL CHECK VALVE						
PRESSURE SENSOR	7		X	NONE						
			A	ANALOG 0-200.0 PSI SENSOR						
CHOOSE UP TO 4 SENSORS FOR SUBSECTIONS 8-11. LEAVE UNUSED SUBSECTIONS BLANK.										
SENSORS			8 - SENSOR #1	A - FREE CHLORINE	H - DISSOLVED OXYGEN					
			9 - SENSOR #2	B - COMBINED CHLORINE	I - FLUORIDE					
			10 - SENSOR #3	C - TOTAL CHLORINE	J - DISSOLVED OZONE					
			11 - SENSOR #4	D - pH	K - CHLORINE DIOXIDE					
			12 - 15 - ADDITIONAL SENSORS #5 - #8	E - TURBIDITY	L - PERACETIC ACID					
				F - ORP	M - HYDROGEN PEROXIDE					
				G - CONDUCTIVITY	X - CUSTOM (CALL)					
PLEASE SEE CUT SHEET FOR UPGRADES AND AVAILABLE OPTIONS										

GENERAL SENSOR SPECIFICATIONS	
VOLTAGE:	BUS POWERED (5 VDC)
COMMUNICATIONS:	SERIAL 485
CONNECTIONS:	MB-5 IP67/68
CHLORINE SENSOR SPECIFICATIONS	
MEASURING RANGE:	0.00 to 5.00 PPM
WETTED MATERIALS:	PVC, TEFLON, VITON, EPDM, RYTON
RESOLUTION:	0.01 PPM
POWER:	40 mW
WATER TEMPERATURE SPECIFICATIONS	
MEASURING RANGE:	23 to 131°F
TEMPERATURE INPUT:	PT100 RTD W/ AUTOMATIC COMPENSATION
ELECTRICAL SPECIFICATIONS	
VOLTAGE:	108-132 VAC, 50/60 Hz
MAX POWER CONSUMPTION:	240 WATTS @ 120 VAC
HEATER SIZE:	150 WATTS WITH FAN
HEAT TRACE SIZE:	3 WATTS PER FOOT (LODGED)
CONTROL POWER SUPPLY SPECIFICATIONS	
SUPPLY VOLTAGE:	90-264 VAC
INPUT FREQUENCY:	47-63 Hz
HOLD-UP TIME:	V1 = 115 VAC - 12 ms
	V1 = 230 VAC - 60 ms
EFFICIENCY:	86%
OUTPUT VOLTAGE:	24 VDC
RATED CONTINUOUS LOADING:	2.5 A @ 24 VDC
MAX POWER:	60 WATTS
PLC SPECIFICATIONS	
OPERATING VOLTAGE:	20.4 - 28.8 VDC
POWER CONSUMPTION:	215 mA @ 24 VDC
INPUTS:	(10) 24 VDC
ANALOG INPUTS:	(2) 10-BIT RESOLUTION, 4-20 mA
OUTPUTS:	(6) INDIVIDUALLY ISOLATED RELAY
NON-VOLATILE MEMORY:	120K DYNAMIC DATA
REMOVABLE MEMORY:	STANDARD MICRO SD CARDS (UP TO 32 GB)
COMMUNICATIONS:	RS-232 OR RS 485 PORT AND OPTIONAL ETHERNET/IP
OTHER SPECIFICATIONS	
MAX PRESSURE:	220 PSI
SAMPLE FLOW RATE:	1 FLOWCELL-UP TO ~10 GALLONS PER HOUR
FLUSH FLOW RATE:	UP TO ~200 GPM
WEIGHT:	~70 LBS
MINIMUM TEMPERATURE DESIGN:	CC: -23°C OR -10°F
CERTIFICATIONS:	AIS, ARRA, NSF/ANSI 372

OTHER SPECIFICATIONS AVAILABLE UPON REQUEST

Intelligent Flushing Station (IFS) shall be installed in the following location(s): _____

A 2" stainless steel MIP inlet will lead vertically to the bottom of a 2" flushing valve. The flushing valve shall control the flow of water through the hydrant and its diaphragm with the extension and retraction of a DC latching solenoid. Flushed water shall flow from the flushing valve through a self-draining tee and a 2" PVC ball valve. From the 2" PVC ball valve, a 2" stainless steel quick disconnect shall connect to a PVC arm and the flushed water shall discharge to the 6" sewer pipe through a removable 2" stream shaper to reduce splashing of the discharged water and allow removal of debris. Removal of the 2" valve and assembly shall be possible via an o-ring connector located beneath the valve after the above ground disconnection of the sampling line, heat trace junction box, and the stainless steel access plate. Valve assembly shall be housed in a PVC enclosure and each unit shall be self-draining, non-freezing. The sampling line shall be looped with self-regulating heat trace running inside of foam pipe insulation vertically along the valve assembly body.

A 3/8" copper tubing sampling line shall be plumbed below the flushing valve and connect to a 1/4" ball valve to allow the flow of water into the sampling assembly. A Y-strainer shall be located immediately after the ball valve for maintenance purposes. From the Y-strainer, a sampling point with valve shall be provided to allow a dedicated sampling point. A sampling valve shall be included to control the flow of water through the IFS with the extension and retraction of a DC latching solenoid. Both solenoids shall have no loose parts when removed from their respective valves. The sampling valve shall control the flow of water to a pressure regulating valve (PRV) and through a node based flowcell that can house up to 4 plug-and-play sensors. As an upgrade, a second flowcell, increasing the number of available sensor ports to 8, shall be added to the right of the primary flowcell behind the control panel and filling out the appropriate sensors in the Product Ordering Guide for subsections 12-15. The node based Modbus sensor(s) shall be serially (RS485) connected to a hub and then to the PLC. The specified chlorine sensor shall be amperometric using a membrane sensor which measures chlorine directly without the use of reagents. From the node based flowcell, the water will plumb away through 1/4" plastic tubing out of the top of the flowcell and empty into the 6" sewer pipe. The sample used for water quality monitoring shall not be altered by adding any chemicals or reagents to the sample stream.

The IFS to be installed on the water lines mentioned above shall use a PLC to control the intelligent blow-off of water to maintain chlorine residual levels while collecting data into local data tables (viewable at the site) and/or a removable micro SD card in a .CSV file (removable and viewable in Excel). The IFS shall have the capability to monitor either the free, combined, and/or total chlorine levels in a water distribution system. The unit shall also allow the user to manually flush water from the line with the simple push of a button, allow a maximum of 8 intelligent sampling times per day, have a max flush length per sampling time, and allow the end user to program the minimum and desired chlorine levels.

Unit shall be upgradeable to use a Sierra Wireless RV50 wireless gateway commissioned with an active 2FF SIM on an M2M profile through the customer's cellular carrier (Sprint, Verizon, AT&T, etc.) The RV50 shall forward the information from the PLC to the cellular network where it may be controlled and/or accessed by the customer on a device (smart phone, tablet, laptop, existing SCADA system, etc.) that can connect to the internet. Firewalls and security to be coordinated between Kupferle and the end user.

The IFS shall be enclosed in an insulated (R9 rating) and powder coated lockable housing with one access panel on the front of the unit. The enclosure shall be lockable by using a pair of stainless steel hasps on the short sides of the enclosure. The IFS shall include a 150 Watt high-efficiency fan heater and 4 separate thermostats (1 located in each corner) to account for any possible drafts by the enclosure access panel. To power the device, a 120 VAC source will need to be provided by the customer. Final power input to be further coordinated between customer and manufacturer with the sensors, PLC, and the necessary controls for the solenoid, being powered from this connection.

Unit model # shall be 9800i-CC-120-*. *-X-*. ***** with *'s specified in accordance with the product ordering guide as manufactured by Kupferle Foundry Company, St. Louis MO, or approved equal.

NOTES	
A	NOT ALL WIRES AND PIPING SHOWN FOR CLARITY PURPOSES.
G	ITEM TO BE PROVIDED BY OTHERS.
M	EXPANDING SPRAY FOAM INSULATION TO BE SPRAYED UNDER THE ENCLOSURE AFTER INSTALLATION.
P	KUPFERLE RECOMMENDS THE INSTALLATION OF A 6" DWV P TRAP.
Q	CONDUIT UP TO ENCLOSURE TO GO DOWN TO A DEPTH OF 18" BELOW GRADE PER NEC ARTICLE 300.5.

	INITIALS	DATE
DRAWN	JRG	10/31/18
APPROVED	DCL	2/11/19
MODIFIED		

SHEET SIZE	SCALE
B (11x17)	VARIABLES

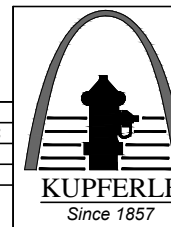

2511 NORTH 9TH STREET
ST. LOUIS, MO 63102
1-800-231-3990
FAX 314-231-2820
www.hydrants.com

DD/MM/YY	ISSUED FOR ...
DATE	STATUS / REVISION